



21B - 121B - 221B Loaders

Table of contents

DIVISION/SECTION	SECTION No.	REFERENCE No.
1 GENERAL INFORMATION		
Safety, General Information and Torque Settings.....	1001	7-57890GB
Specifications:		
21B loader	1002	7-57900GB
Specifications:		
121B loader: up to Serial Number DAH 1218599		
221B loader: up to Serial Number DAH 2218599.....	1002	7-58160GB and 7-58160R1GB
Specifications:		
121B loader: Serial Number DAH 1218600 and after		
221B loader: Serial Number DAH 2218600 and after.....	1002	7-84250GB
2 ENGINE		
Engine Specifications.....	2401	7-57910GB
Cylinder Head and Valve Assembly	2415	7-57920GB
Cylinder Block	2425	7-57930GB
Lubrication System	2445	7-57940GB
Cooling System.....	2455	7-57950GB
Turbocharger.....	2465	7-57960GB
3 FUEL SYSTEM		
Fuel System and Filter	3410	7-57970GB
Injection Pump	3412	7-57980GB
4 ELECTRICAL SYSTEM		
Electrical Schematics:		
21B loader		
121B loader: up to Serial Number DAH1218599		
221B loader: up to Serial Number DAH 2218599.....	4001	7-57990GB and 7-57990R1GB
Electrical Schematics:		
121B loader: Serial Number DAH 1218600 and after		
221B loader: Serial Number DAH 2218600 and after.....	4001	7-84110GB
Starter motor.....	4003	7-57800GB
Alternator	4004	7-58010GB
5 STEERING SYSTEM		
Rotary Control Valve	5001	7-58020GB
6 TRANSMISSION COMPONENTS		
Travel Reduction Gear: 21B loader.....	6001	
Rear Axle and Transfer Box	6002	
Front Axle.....	6003	
7 DRIVE TRAIN		
Master cylinder: 21B loader	7001	7-58070GB
Master cylinder: 121B - 221B.....	7001	7-58140GB

 Section to be distributed at a later date

DIVISION/SECTION	SECTION No.	REFERENCE No.
8 UNDERCARRIAGE HYDRAULICS		
Checks, Adjustments and Hydraulic Schematics:		
21B loader		
121B loader: up to Serial Number DAH 1218599		
221B loader: up to Serial Number DAH 2218599	8001	7-58080GB and 7-58080R1GB
Checks, Adjustments and Hydraulic Schematics:		
121B loader: Serial Number DAH 1218600 and after		
221B loader: Serial Number DAH 2218600 and after.....	8001	7-84120GB
Variable Displacement Pump: 21B loader.....	8002	7-58090GB
Variable Displacement Pump: 121B - 221B loaders	8002	7-58100GB
Travel motor:		
21B loader: Up to Serial Number DAH 216074	8003	7-58170GB and 7-58170R1GB
Travel motor:		
21B loader: Serial Number DAH 216075 and after.....	8003	7-58030GB and 7-58030R1GB
Travel motor:		
121B loader: up to Serial Number DAH 1216059		
221B loader: up to Serial Number DAH 2216059.....	8003	7-58180GB and 7-58180R1GB
Travel motor:		
121B loader: up to Serial Number DAH 1216060 and after		
221B loader: up to Serial Number DAH 2216060 and after.....	8003	7-58150GB and 7-58150R1GB
Control Valve: 21B loader.....	8004	7-58110GB
Control Valve: 121B - 221B loaders	8004	7-58130GB
Cylinders	8006	7-58120GB

Section

1001

SAFETY, GENERAL AND STANDARD TORQUE SETTINGS

TABLE OF CONTENTS

SAFETY	3-4
GENERAL	5
USING TORQUE WRENCHES	6
COMPONENT TIGHTENING SEQUENCE	7
STANDARD TORQUE SETTINGS FOR ASSEMBLIES USING SCREWS	8

**Thanks very much for your reading,
Want to get more information,
Please click here, Then get the complete
manual**

JustClickHere 

NOTE:

**If there is no response to click on the link above,
please download the PDF document first, and then
click on it.**

**Have any questions please write to me:
admin@servicemanualperfect.com**

SAFETY



*This symbol means **WARNING! TAKE CARE! YOUR SAFETY IS CONCERNED.** The message which follows this symbol contains important safety messages. Read it carefully. Make sure that you have fully understood the causes of possible serious injuries.*

To avoid all accidents, follow the safety notes in this section and other notes that you will find throughout this manual.



PDG0328



Read the operator's manual to familiarize yourself with the controls and their correct use.



The operator must be seated in the operator's seat to operate the machine and the attachments controls. Any other way of proceeding can cause a serious accident.



This is a machine for use by one single person. No passengers are allowed.



Before starting the engine, read the safety messages shown in the operator's manual. Read all decals concerning safety which are mounted on the machine. Make sure that no-one is within the working area. Learn to use the controls in a safe manner before working with them. You must understand and follow the manufacturer's instructions for the operation and maintenance of the machine and respect current laws and regulations. Operator's manuals and service manuals can be ordered from you CASE Dealer.



You risk an accident if you wear clothing which is too loose or if you do not use the safety equipment which is appropriate for your work. Always wear clothing which will not catch on objects. Among extra safety equipment which may be necessary are a helmet, safety shoes, ear, eye and face protection, thick gloves and reflective clothing.



When working near the fan, with the engine running, do not wear loose clothing and be very careful.



*When making inspections or tests on hydraulic equipment, follow the procedures to the letter. **DO NOT** modify the procedures.*



When this machine's hydraulic cylinders are operated to check for correct operation or to bleed air from the circuit, make sure that no person is standing in the working range.



Use heat-protective gloves when handling hot parts.



Lower all the attachments to the ground or use safe supports for the attachments before starting maintenance and repairs.



Splashes or very fine jets of hydraulic oil under pressure can penetrate the skin and cause serious infection. If hydraulic oil under pressure penetrates the skin, medical treatment must be sought immediately. Keep all hoses and pipes in good condition. Ensure that all unions are tightened. Replace any hose or pipe which is defective or likely to become defective. DO NOT use your hands to check for leaks, use a piece of cardboard or wood.



When replacing a heat treated shaft, such as the pivot shaft or any other heat treated shaft, use a copper or bronze headed mallet, or use a piece of copper or bronze between the shaft and the hammer or mallet.



When using a hammer to install pivot shafts, accessories operated by compressed air or when using a grinder, suitable eye protection must be worn, completely covering the eyes (work goggles or any other approved form of protection).



To lift the wheels or tracks off the ground, use jacks, chain lifting devices and make sure that the ground is suitable. Always use suitable, safe supports to support the machine.



When servicing or repairing the machine, there must be no oil, grease, tools etc. on the workshop floor, cab floor or on the steps. If necessary, use a substance to absorb oil and wear workshop clothing. Always use safe methods.



Some components of this machine are very heavy. Use suitable lifting equipment or request help as shown in this manual.



Exhaust gases can cause death. If it is necessary to run an engine in an enclosed space, the exhaust gases must be evacuated from that space by an evacuation pipe. Open the doors and allow air from outside into the area where the engine is running.



When battery electrolyte is frozen, it may explode : (1) if you try to charge it or (2) to start up the engine using a booster source of electrical power. To prevent the electrolyte from freezing, make sure the battery is always fully charged. If these instructions are not observed, there is a risk of injury to persons in the vicinity.



Batteries contain acid and explosive gases. Explosions can be caused by sparks, flames or poorly connected cables. See the Operator's Manual for correct connection of battery cables on this machine. If these instructions are not observed, serious injury can result.

GENERAL

CLEANING

Clean all metal parts except bearings in white spirit or use steam. Do not use caustic soda when steam cleaning. After cleaning dry and oil all parts. Clean oil passages using compressed air. Clean bearings in kerosene. Dry them completely and then lubricate them.

INSPECTION

Check all parts once they have been removed. Replace all parts showing wear or damage. Shallow pitting or scratches can be removed by honing or with a cloth dipped in polishing rouge. A full visual inspection to detect wear and pitting and the replacement of parts as required will prevent premature failures.

BEARINGS

Check that the bearings turn freely. If there is too much float or if they do not operate smoothly, they must be replaced. Clean bearings using a good solvent or kerosene and allow them to dry in the air. **DO NOT DRY BEARINGS WITH COMPRESSED AIR.**

NEEDLE BEARINGS

Before pressing needle bearings into a bore, always remove any metal protrusion from the bore or its surroundings. Before using a press to install bearings, coat the inside and the outside of the bearings with Vaseline.

GEARS

Check all gears for wear and damage. Replace worn or damaged gears.

SEALING RINGS, O-RINGS AND GASKETS

Always install new sealing rings, O-rings and gaskets. Coat sealing rings, O-rings and gaskets with Vaseline.

SHAFTS

Check all shafts showing signs of wear or damage. Check that the surface of the shaft where a bearing or sealing ring is fitted shows no signs of damage.

PARTS

Always install CASE genuine parts. When making out a parts order, consult the Parts Catalogue to be able to give the correct part numbers for the genuine CASE part. Failures due to the use of parts other than genuine CASE parts are not covered by the warranty.

LUBRICATION

Only use oils and lubricants specified in the Operator's Manual or Service Manual. Failures caused by the use of non-specified oils and lubricants are not covered by the warranty.

USING TORQUE WRENCHES

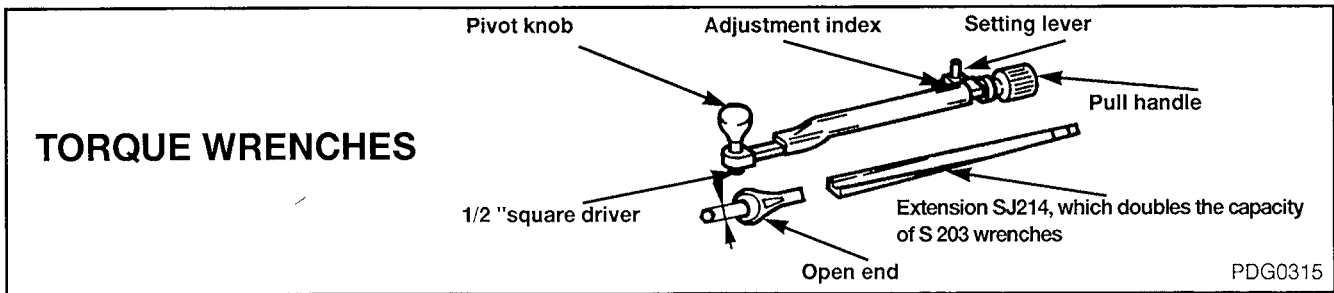

METHOD OF USE

a - Hold the wrench by the knob provided.

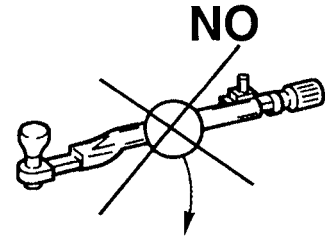
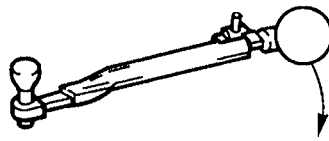

b - When tightening, keep the wrench perpendicular to the bolt axis.

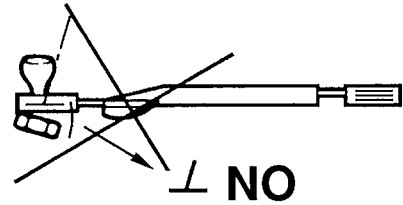
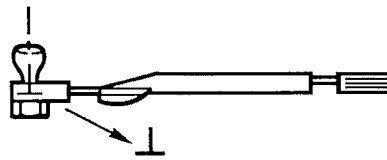

HAND

c - Use the pivot knob to maintain the torque application point.

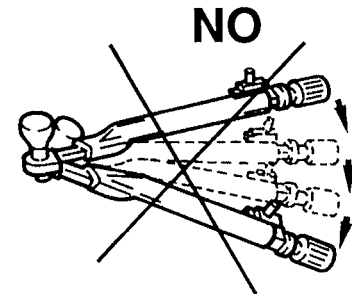
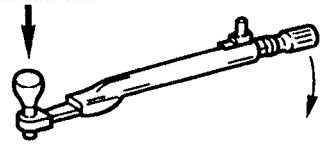

d - Tighten gradually

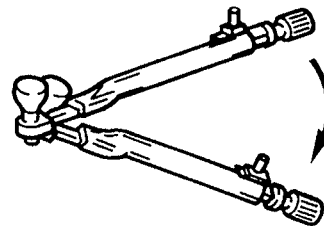

e - Use socket or open ended wrench to the correct dimension on the flat of the screw head.

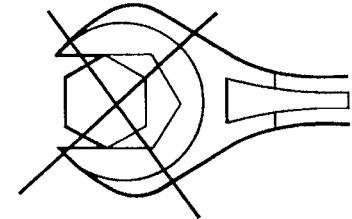
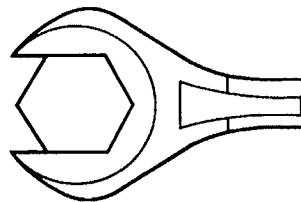

COMPONENT TIGHTENING SEQUENCE

TORQUE WRENCHES

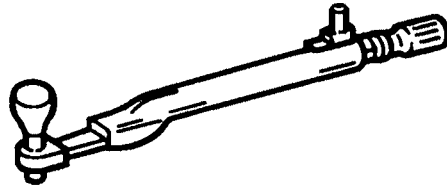

PDG0317

TIGHTENING COMPONENTS

- a - Torque wrench
- Apply the tightening torque following the tightening sequence
- "Cross" tightening or "diagonal" tightening

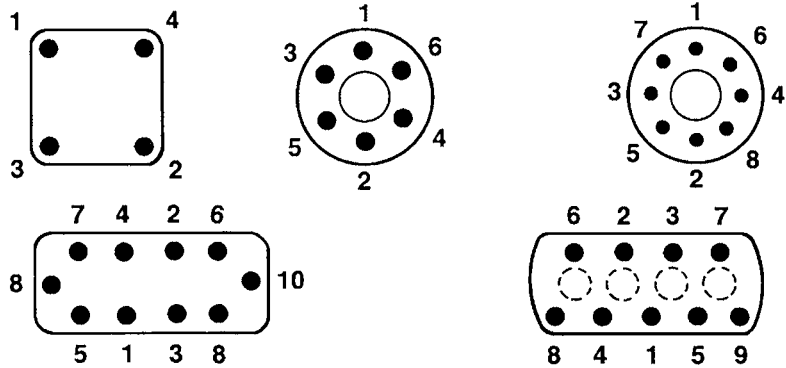

PDG0318

FINAL TIGHTENING

Must be performed in a clockwise sequence

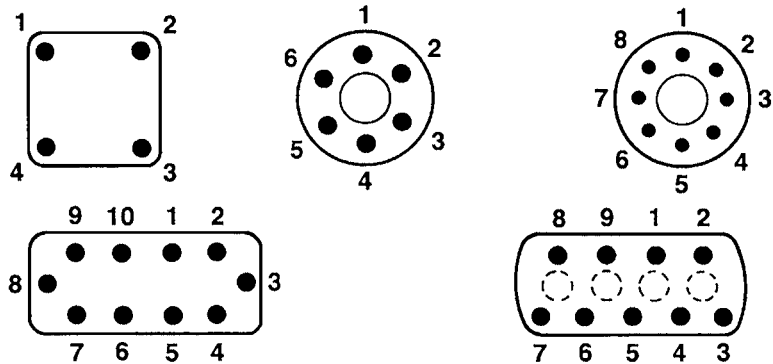

PDG0319

STANDARD TORQUES FOR ASSEMBLIES USING SCREWS

Identification of screws

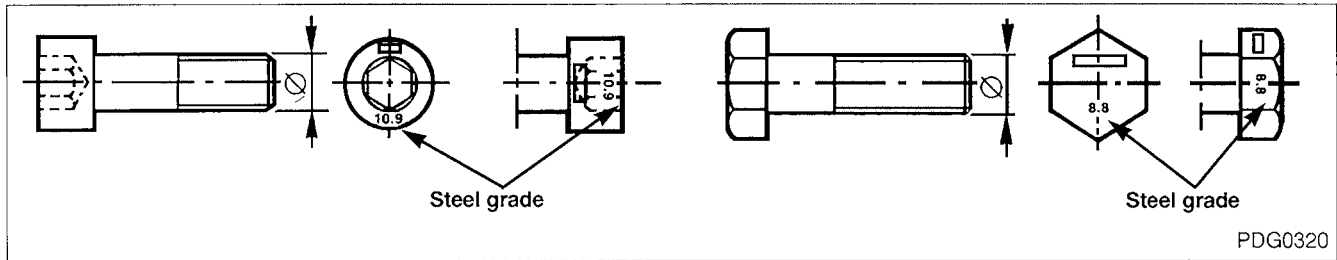

General torques in Nm

Screw grade		Screw diameter									
ISO	DIN	M12	M14	M16	M18	M20	M22	M24	M27	M30	M33
8.8	8G	70	120	180	260	330	440	570	800	1050	1450
10.9	10K	85	150	220	320	410	530	690	1000	1270	1750
12.9	12K	100	180	260	380	490	630	820	1150	1500	2050

Section

1002

SPECIFICATIONS

21B Loader

1002

TABLE OF CONTENTS

MACHINE OVERALL DIMENSIONS	3
ENGINE	4
ELECTRICAL SYSTEM.....	4
TRANSMISSION.....	4
AXLES	4
TYRES	4
BRAKES	5
BRAKES	5
HYDRAULIC SYSTEM	5
CAPACITIES.....	5
PERFORMANCE AND SPECIFICATIONS	6
FLUIDS AND LUBRICANTS.....	8
DETAILED OF SPECIFICATIONS BY COMPONENT	11



This symbol is used in this manual to show important safety messages. Whenever you see this symbol, read the message which follows carefully, since there is a risk of serious injury.

MACHINE OVERALL DIMENSIONS AND WORKING RANGE

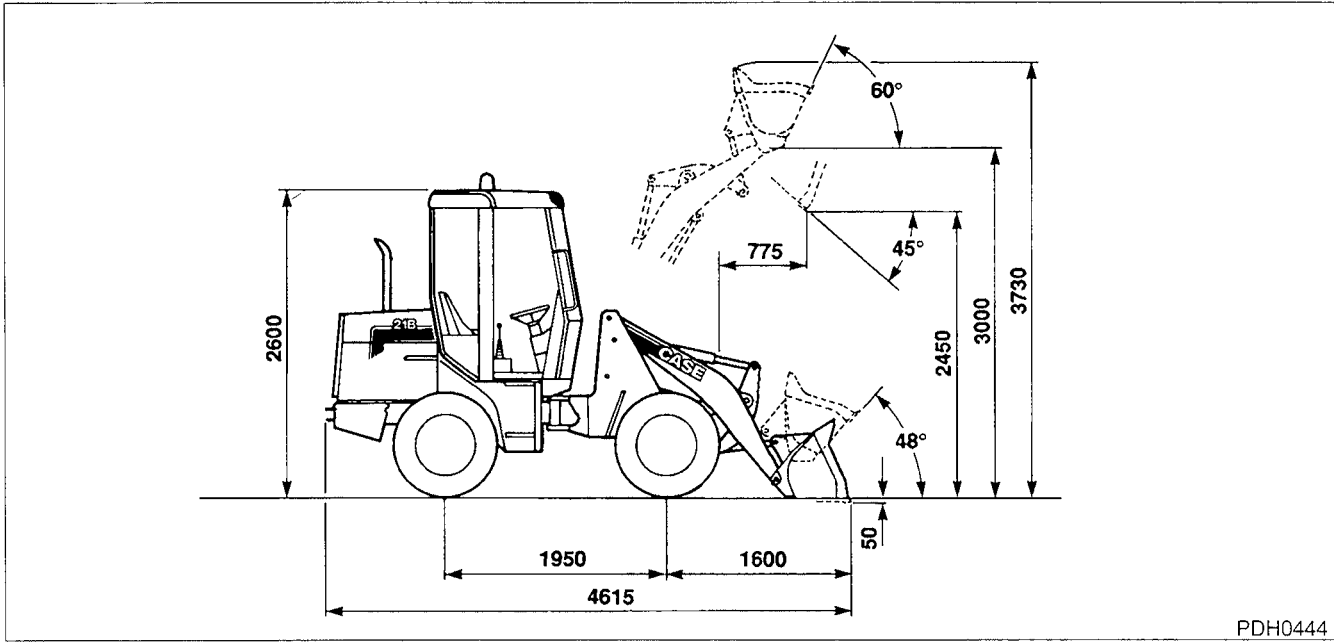

PDH0444

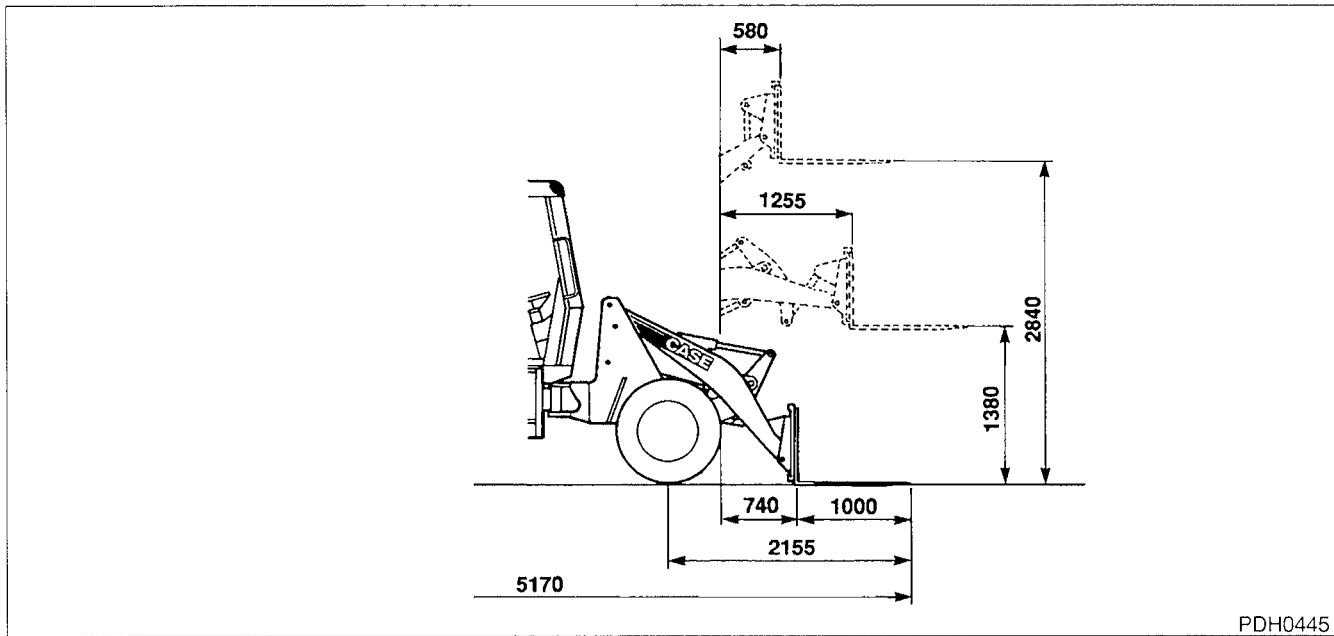

PDH0445

DIESELMOTOR

Make and model	Perkins 504-2
SAE horsepower rating	45 hp (33 kW) at 2500 rpm
DIN 6271 horsepower rating	42 hp (31 kW) at 2500 rpm
EEC 80/1269 horsepower rating	42 hp (31 kW) at 2500 rpm
Maximum torque EEC 80/1269	121 Nm at 2200 rpm
Displacement.....	2000 cc
Number of cylinders	4
Bore x stroke	84.5 x 88.9 mm
Compression ratio.....	17 : 1
Injection system	direct
Air filter	dry type
Restriction indicator on instrument panel.	
Oil filter	screw-on element

ELECTRICAL SYSTEM

Voltage	12 volts
Battery	1 x 12 volts
Alternator.....	45 Amp

TRANSMISSION

Hydrostatic

Closed circuit automatic power regulation.

A single electrically controlled lever selects two forward and reverse speeds plus the direction of travel.

Hydraulic system

Variable displacement piston pump with forced-feed pump, attached to the engine, driven directly by the engine.

Double displacement piston motor.

Interchangeable 10 micron filter on the inlet circuit, with restriction indicator on instrument panel.

Working pressure.....400 bar

Travel speeds

Engine at full speed - 10.5 x 18 tyres

Forward/Reverse direction of travelFirst speed : 9 km/h
 Second speed : 24 km/h
 (special for Germany) : 20 km/h

AXLES

Front axle

Rear axle.....oscillating (+, -) 20°

TYRES

Standard10.5 x 18

BRAKES

Service brake

Hydraulically operated disc brake mounted on the transmission shaft.

Parking brake

Manually operated disc brake mounted on the transmission shaft.

STEERING

Type	Hydraulic
Turning angle	(+/-) 40°
Turning radius:	
Tyre inner 10.5 x 18	1.95 m
Bucket outer	3.80 m
Steering cylinders	double acting
diameter x stroke	65 x 255 mm
Pump	gear type
Flow	28 L/min at 2500 rpm
Steering safety valve pressure setting	140 bar

HYDRAULIC SYSTEM

Double-body gear pump, mounted directly on the end of the transmission pump, with driven directly from the engine.

Flow for loader attachment	50 L/min at 2500 rpm
Flow for steering system	28 L/min at 2500 rpm

Mechanically operated modular type, 3 spool open centre control valves.

Working pressure up to	190 bar
------------------------------	---------

Double acting cylinders with hardened, chromium plated rods.

Arm (quantity 1) (diameter x stroke)	85 x 665 mm
Bucket (quantity 1) (diameter x stroke)	70 x 310 mm

Hydraulic reservoir is common with transmission system.

Filtration of the return circuit using 10 micron interchangeable element filter.

Cycle time (with full bucket)

Raising	4.6 seconds
Lowering (empty bucket)	3.4 seconds
Dumping	1 second
Complete cycle time	9 seconds

CAPACITIES

Fuel tank	50 litres
Hydraulic system	
Total	52 litres
Reservoir	40 litres
Engine with filter	5.5 litres
Axle	
Front	10 litres
Rear	12 litres
Reduction gear	0.5 litres
Brake system	0.2 litres
Cooling system	12 litres

PERFORMANCE AND SPECIFICATIONS

Performance

Standard bucket capacity	0.55 m ³
Breakout force	3510 daN
Tipping load	
In line	2350 kg
Turned 40°	2030 kg
Dimensions and weights	
Track	1.22 m
Ground clearance	0.28 m
Width at tyre outer	1.49 m
Width of bucket	1.60 m
Standard all-up weight	3300 kg
Maximum all-up weight	3650 kg

Specifications

Electrical speed selection

One single lever located near the steering wheel provides electrical selection of speeds and direction of travel.

Smooth controls

One single cross-pattern lever for the loader attachment functions.
The second lever is provided to operate an optional attachment.

Electronic monitoring system

A comprehensive instrument panel is located in front of the operator.
The main functions of the machine are equipped with visual and audible warning devices.

Super comfort cab

Cab, mounted on flexible mountings, to ROPS and FOPS standards, is sound proofed and has large areas of safety glass to give total visibility.
Adjustable suspension seat.
High performance heating and ventilation.

Hydraulically controlled quick hitch

The hydraulically controlled quick hitch is a standard feature. It enables buckets and other tools to be changed in a few seconds.

Quick access

The engine hood lifts open towards the rear and gives total accessibility for inspection and maintenance of the main components.

Equipment

Standard Equipment (French market)

Cab approved to ROPS and FOPS standards.
Two access doors.
Adjustable suspension seat with safety belt.
Ventilation.
Heater and de-mister.
Sound-proofing to European standards.
Front and rear working lights.
Road lights.
Front and rear windshield wiper.
Left and right-hand rear view mirror.
Right-hand horn.
Audible reversing warning.
Instrument panel with electronic monitoring system.
Audible warning (defects in main functions).
Visual bucket position indicator.
Safety prop for loader attachment.
Three spool control valve.
Hydraulically controlled quick hitch.
Lockable caps for fuel tank and hydraulic reservoir.
Towing eye
Sling points.
Counterweight.
Standard tyres.
Steering wheel knob.
Sun visor.
Tilting rotary light.

Optional equipment (French market)

Fourth hydraulic function.
Radio.
Air conditioning.
4 in 1 bucket.
Earthmoving bucket.
High dump bucket.
Side dump bucket.
Mixer bucket.
Pallet forks.
Snow plough blade.
Swivelling dozer blade.
Dozer blade.
Wood grab.
Hydraulic winch.
Snow plough.
Sweeper.
Hand-held hydraulic hammer.
Extra counterweights.

FLUIDS AND LUBRICANTS

The fluids and lubricants must correspond to the correct specifications for each type of use.

It is mandatory to observe the conditions of use of the various fluids and lubricants.

Hydraulic fluid

Use CASE POCLAIN ELF fluid, or if not available, a fluid corresponding to the standard FORD M-2C-86B ALLISON C3.

Type of fluid to be used depending on ambient temperature.

Temperate countries

-20°C to +40°C	Ref.
50 kg can	J3205
80 kg drum	G3203

Biodegradable fluid :

This yellow coloured fluid can be mixed with standard fluid. When using this fluid, we recommend that the hydraulic system should first be completely drained.

Kleines Faß 21 kg	B503301
180 kg drum	Q1003274

Hot countries

0°C to +60°C	
50 kg can	U1003209
180 kg drum	C1003239

Cold countries

-40°C to +20°C	
50 kg can	V1003210
180 kg drum	D1003240

Transmission component oil

This oil is used for housed transmission components.
TRACTELF SF3 or if not available FORD M-2C-86B ALLISON C3.

Grease

Use EP2 or EP0 grease or if not available a grease corresponding to the following standards and specifications : EP LITIO NGLI 2.

Type of grease to be used depending on ambient temperature.

Temperate countries

-20°C to +60°C	
GREASE EP2	Ref.
0.5 L cartridge	F1003242
23 kg can	L1003247
50 kg can	K1003246

Cold countries

-40°C to +20°C	
GREASE EP0	
0.5 L cartridge	G1003243
23 kg can	S1003230
50 kg can	N1003226

Brake fluid

Use a brake fluid corresponding to D.O.T.4 SAE J1703F standards and specifications. It must not be mixed with mineral oil or silicone oils.

Engine oil

CASE N°1 engine oil is recommended for your engine. This oil ensures correct lubrication of your engine under all operating conditions.

If it is not possible to obtain CASE N°1 multipurpose or Performance engine oil, only use oils which correspond to the API/CE category.



EO1730

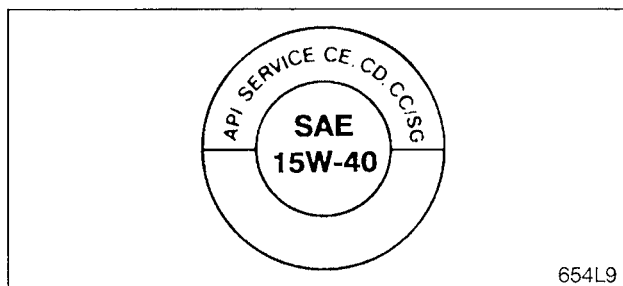

654L9

NOTE : Do not add any performance additive or other additive to the engine oil sump. Oil change intervals as shown in this manual are based on tests which have been performed with CASE lubricants.

Oil viscosities/Range of use for oils

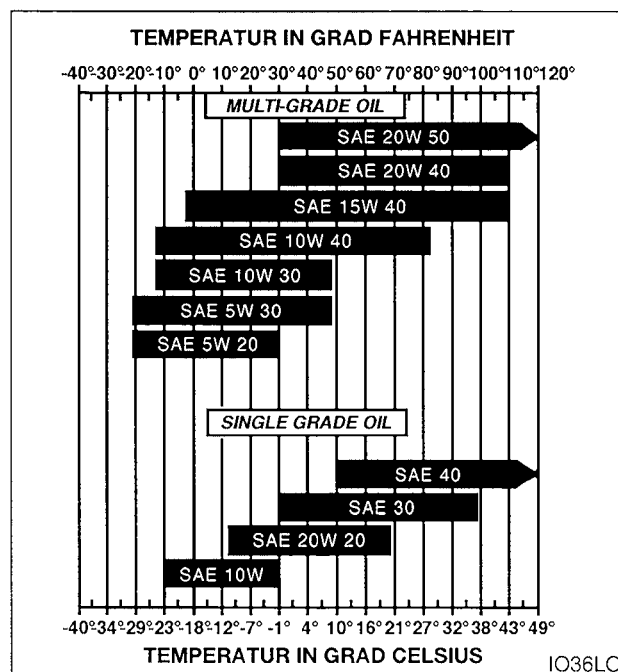

IO36LO

Fuel

The fuel to be used must correspond to the D975 of the American Society for Testing and Materials (ASTM).

Use N°2 fuel. The use of other types of fuel can cause a loss of engine power and excessive fuel consumption.

In cold weather, it may be temporarily permitted to use a mixture of N°1 and N°2 fuels. Consult your fuel supplier.

If the temperature falls below the fuel cloud point (point at which wax appears), crystals of wax in the fuel will cause a loss of engine power or make it impossible to start the engine.

IMPORTANT : In cold weather, refill the fuel tank after each working day to prevent the formation of condensation.

Fuel storage

Prolonged fuel storage tends to cause the accumulation of foreign bodies or condensation water in the storage tank. Many engine failures are caused by the presence of water in the fuel.

The storage tank must be located outdoors and the fuel should be kept at the lowest possible temperature. Drain off condensation water at regular intervals.

Antifreeze/Anticorrosion

Use antifreeze all the year around to protect the cooling system from corrosion and any risk of freezing.

For environments with a temperature above -36°C , use a mixture of 50% ethylene glycol antifreeze.

For environments with a temperature below -36°C , a mixture of 40% water and 60% antifreeze is recommended.

DETAILED SPECIFICATIONS BY COMPONENT

Hydrostatic pump.....	12
Hydraulic steering and brake pump	12
Hydraulic loader pump	12
Hydraulic filter	12
Loader control valve.....	12
Steering control valve	12
Master cylinder.....	13
Lift cylinder.....	13
Bucket cylinder.....	13
Steering cylinder	13
Hydraulic quick hitch cylinder.....	13
4 in 1 bucket cylinder	13
Hydraulic motor.....	13
Front axle.....	14
Rear axle.....	14
Hydraulic reservoir	14
Water/Oil cooler	14
Battery.....	14
Alternator	14
Starter motor	14